

- (73) Kiss, *Chem. Abs.*, 18, 2277 (1924).      (75) Trautz and Schleuter, *Ibid.*, 136, 1  
(74) Trautz and Gerwig, *Z. anorg. Chem.*, (1924).  
134, 409 (1924).      (76) Noyes, *Berichte*, 57B, 1233 (1924).

COLLEGE OF PHARMACY,  
UNIVERSITY OF WASHINGTON,  
SEATTLE, WASH.  
August 10, 1925.

---

## THE DETERMINATION OF ACIDITY.

BY ERNEST LITTLE.\*

The subject of electrometric titrations has recently been discussed in the publications of the AMERICAN PHARMACEUTICAL ASSOCIATION by Kolthoff,<sup>1</sup> Popoff and McHenry,<sup>2</sup> Wagener and McGill,<sup>3</sup> Giesy,<sup>4</sup> Krantz<sup>5</sup>, and others. In these articles many practical applications of the hydrogen electrode have been indicated but no comprehensive presentation of the subject as applying to acidity determinations has been made. It occurred to the writer, therefore, that it might be of value to have presented a complete discussion of "The Determination of Acidity," showing recent applications of physical chemical measurements and bringing together in one paper various phases of the subject which are presented in more detail in various scattered sources. All data presented in this article are original and all graphs or curves were developed by the writer as a result of his own experimental work.

It was not many years ago that our knowledge of acidity determinations was considered to be quite complete, due primarily to the fact that it was so very limited. An acidity determination consisted merely of adding to a measured quantity of the acid material a mysterious substance called an indicator, which was supposed to possess one color in an acid solution and quite a different color in an alkaline solution, and then running in standard alkali until the desired color change occurred. Thus the acidity was determined. It was, of course, observed that in some acid solutions the indicator functioned well and in others poorly, but these facts caused no great concern. In order to determine which indicator might be most suitable for a particular titration the scientific method used was to try in turn a great number of indicators and observe which one gave the best color change and hence seemed most desirable. The crudity of this procedure has been recognized and it is no longer used, but it is at least still of historical interest.

It was soon observed that it is possible to have a solution which is acid to one indicator and alkaline toward another. For example, a dilute solution of acetic acid which has its ionization repressed by the addition of sodium acetate may be acid toward phenolphthalein, alkaline toward methyl orange and neutral toward litmus. This information constituted a tremendous advance and showed at once that various indicators change at different degrees of acidity or concentration of hydrogen ion, represented by (H<sup>+</sup>). The (H<sup>+</sup>) means simply the number of hydrogen ions per liter. The degree of acidity is also sometimes represented in terms of the logarithm of the reciprocal of this value, as recommended by Sorensen,<sup>6</sup> and is known as the  $p_H$  value.

---

\* Professor of Chemistry, New Jersey College of Pharmacy, Newark, N. J.

The question which now arises is, how can we determine at what ( $H^+$ ) a particular indicator changes? To answer this question satisfactorily we must first introduce the Nernst formula and the use of the hydrogen electrode. Here we will start at the beginning. We are all familiar with the electromotive series and have learned that it is an arrangement of the metals in the order of their decreasing chemical activity. Metals of the nature of sodium and potassium located at the top of the series form very stable compounds and pass readily from the elementary to the ionic state, while gold and platinum at the bottom of the series are found in compounds which are easily reduced and pass readily from the ionic to the elementary condition. The force tending to drive a metal into the ionic condition is spoken of as its solution tension. The electrolytic potential differences for some of the more common elements, measured in volts for a one-molar metallic ion concentration in terms of hydrogen equals zero, are as follows.

Metal.	Volts.	Metal.	Volts.	Metal.	Volts.
K	+3.20	Zn	+0.770	Ag	-0.798
Na	+2.82	Fe	+0.660	Pt	-0.863
Ca	+2.56	H	0.000	Au	-1.079

If now we place a piece of zinc in a very dilute solution of a zinc salt this electro-positive element will pass into the ionic condition thus leaving the zinc negatively charged. This negatively charged zinc will attract to it or hold in its immediate vicinity positively charged zinc ions and a difference of potential will exist between this negatively charged metal and the positive solution surrounding it. The zinc ions in solution give rise to a counter pressure, which is spoken of as the osmotic pressure, which tends to drive zinc ions back into the elementary condition. The formation of zinc ions, however, continues to predominate until the ( $Zn^{++}$ ) has reached such a value that the osmotic pressure becomes equal to the solution tension. Then the speeds of the reaction in the two directions are equal to each other, dynamic equilibrium is established and no difference of potential between the metal and its solution exists.

The Nernst formula<sup>7</sup> is a quantitative expression of the difference of potential existing between a metal and a certain concentration of its ion. Nernst first determines the osmotic work done in changing one gram-ion weight of a metal from its solution pressure, which is represented by  $P$ , to the osmotic pressure of the solution which is represented by  $p$ . This is represented by the expression

$$\text{Isomotic Work} = \int_p^P v dp$$

$$\text{but } pv = RT \text{ or } v = \frac{RT}{p}$$

$$\text{therefore Osmotic Work} = RT \int_p^P \frac{dp}{p}$$

$$\text{Integrating we obtain Osmotic Work} = RT \log e \frac{P}{p}$$

This osmotic work is equal to the electrical energy gained which is represented by  $nFE$  where  $n$  is the valence change,  $F$  is the faraday and  $E$  is the potential difference existing between the metal and its solution. Hence we obtain the expression

$$nFE = RT \log e \frac{P}{p}$$

Rearranging this expression, changing to electrical units completely and to logarithms to the base ten we obtain

$$E = \frac{2}{96,540 \times n \times 0.4343 \times 0.2394} T \log \frac{P}{p}$$

96,540 is the value of the faraday,  $n$  the valence change, 0.4343 the log. factor and 0.2394 a factor to complete the change to electrical units. We now invert so that the algebraic sign of the above expression will be the same as the positive or negative charge on the metal and express in terms of concentrations which are proportional to the pressures.

$$E = \frac{2}{96,540 \times n \times 0.4343 \times 0.2394} T \log \frac{c}{C}$$

$C$  for any element is a constant at a definite temperature and is the concentration of the ion which will give zero potential between the solution and the metal. Recognizing this fact and combining the above constants we obtain for a temperature of 25° C. the final expression

$$E = \frac{0.0591}{n} \log. \frac{c}{K}$$

The application of the above discussion to the hydrogen electrode is at once apparent. The hydrogen electrode is simply a platinum electrode with the end coated with platinum black in order to have a larger surface exposed. This platinum black is bathed with pure hydrogen gas which dissolves physically in the platinum or is adsorbed by it. We have, therefore, for all practical purposes, an electrode made of hydrogen. This electrode when immersed in any solution will set up an equilibrium with the ( $H^+$ ) there existing and there will be a difference of potential existing between the electrode and the solution which is expressed by the Nernst formula, just as it is for a zinc or any other metallic electrode. For the hydrogen electrode then this formula at 25° C. becomes

$$E = \frac{0.0591}{1} \log. \frac{[H^+]}{10^{-4.72}}$$

This expression, however, represents a polar potential which is not easily measured experimentally.

It is much more convenient to use the hydrogen electrode in connection with a calomel half cell in which there is also a polar potential existing between mercury and mercurous ions. The difference of potential between these two half-cells can now be easily measured. We must first, however, determine the potential of the calomel half cell against what is known as a null electrode and thus obtain a standard of potential. One of the earlier used null electrodes is the dropping electrode as recommended by Helmholtz.<sup>8</sup> Objections to the use of the dropping electrode have been presented by Nernst and others, but it will serve our purpose in presenting the principle involved. Nernst suggests that the hydrogen electrode immersed in a one molar ( $H^+$ ) be taken as the standard and the equation  $E = 0.00019837 T \log \frac{1}{[H^+]}$  be used. Here, however, experimental difficulties creep

in and rather than use two hydrogen electrodes, one hydrogen electrode is used in connection with a calomel cell. In order to use the above formula, we should know the potential difference between the calomel electrode and a one-molar hydrogen electrode. As it is exceedingly difficult to prepare a solution of  $(H^+)$  equal exactly to one, it is customary to determine the potential difference between the calomel electrode and some lower, known  $(H^+)$  and then from this data calculate what the potential difference between the calomel electrode and the one-molar hydrogen electrode would be. In the dropping electrode a funnel with a capillary opening extends below the surface of a normal solution of potassium chloride which also contains  $Hg^{+2}$  and has a layer of mercury on the bottom of the vessel. As the little globules of mercury fall from the funnel into the solution they become positively charged due to the fact that the osmotic pressure exceeds the solution tension. These positively charged mercury globules will attract anions to their surface and carry them from the solution to the mercury below. When they come in contact with the mercury layer, their capacity is diminished due to a greatly decreased surface. The result is that mercurous ions equal to the number of anions present are given back to the solution. When the osmotic and solution pressures become equal, the process stops and the mercury at the bottom will have the same potential as the solution. The difference of potential between the mercury layer and the mercury in the funnel is then measured and recorded as the potential of the molar potassium chloride calomel half cell. At  $25^{\circ} C.$  this standard of potential is found to be 0.5648 volts.

This normal potassium chloride electrode is then placed in circuit with a saturated potassium chloride calomel half cell and the difference of potential between these two electrodes is found to be 0.0382 volts at  $25^{\circ} C.$  This gives a value of  $0.5648 - 0.0382$  or 0.5266 volts for the saturated potassium chloride calomel half cell at  $25^{\circ} C.$

This standard of potential can now be used with the hydrogen electrode to determine the  $p_H$  value of any solution. The hydrogen electrode is put in the solution being tested and is placed in circuit with the saturated potassium chloride calomel electrode. The difference of potential between these two electrodes is now measured. Let it be represented by  $E$ . Then  $E = 0.5266 - \text{hydrogen electrode polar potential, or}$

$$E = 0.5266 - \frac{0.0591}{1} \log. \frac{[H^+]}{10^{-4.72}}$$

Rearranging we obtain

$$\log. \frac{1}{[H^+]} \text{ or } p_H \text{ value} = \frac{E - 0.2477}{0.0591}$$

This equation represents a straight line relationship between  $E$  and  $p_H$  values and can be plotted as shown in Graph No. 1. By use of this graph  $p_H$  values corresponding to observed voltages can be quickly determined.

Two methods of determining  $E$  are now in general practice. One is the millivoltmeter set up as recommended by Hildebrand<sup>9</sup> and the other involves the use of a potentiometer. The Hildebrand set up is shown by the following diagram.

(A) is a storage battery any fractional part of which may be utilized between points (I) and (C) by moving the sliding contact (C), thus increasing or decreasing

resistance offered by (B). (H) is a hydrogen electrode and (F) is a calomel half cell. Together these constitute a cell which is so arranged as to oppose the difference of potential from the storage battery (A). The operation of the set-up is simple and consists of moving the sliding contact (C) until there is no deflection of the galvanometer (G) when contact is made at (L). This indicates that the difference of potential (E) between the hydrogen electrode and the calomel cell is equal to the difference of potential between the points (I) and (C) and is the potential registered by the millivoltmeter (D).

The essential parts of the potentiometer set up are given below as outlined by Klopsteg.<sup>10</sup> The standard cell represented is a standard Weston cell. The galvanometer used is a high sensitivity galvanometer. The source of current is

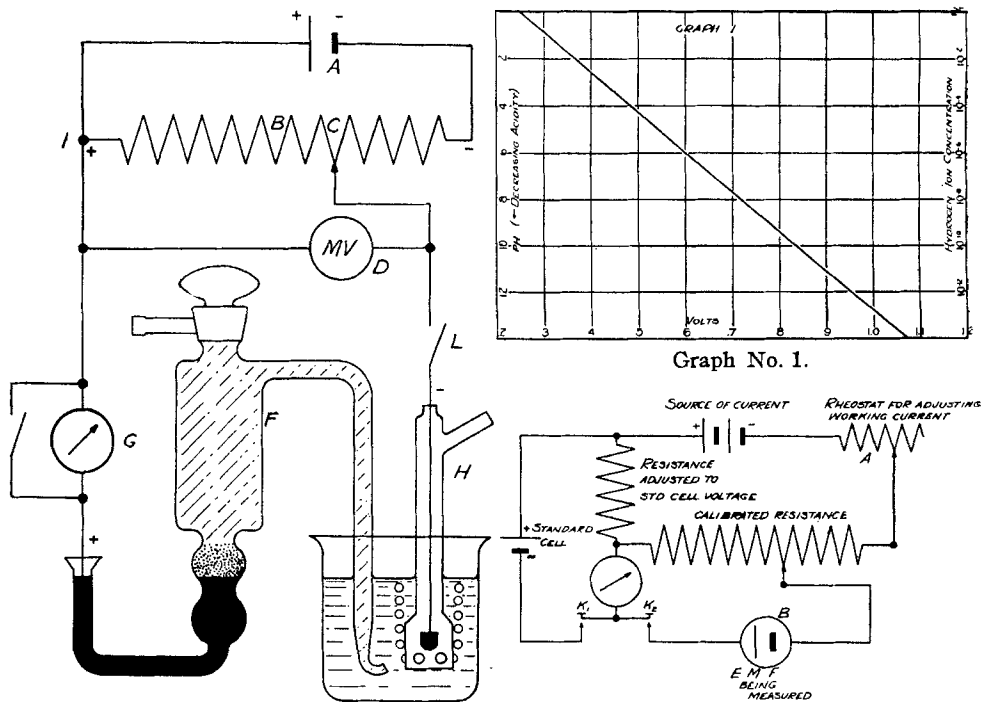
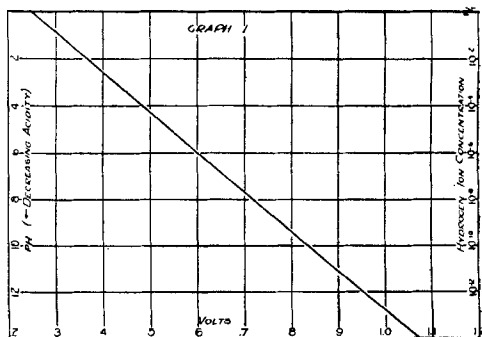

Fig. 1.



Graph No. 1.

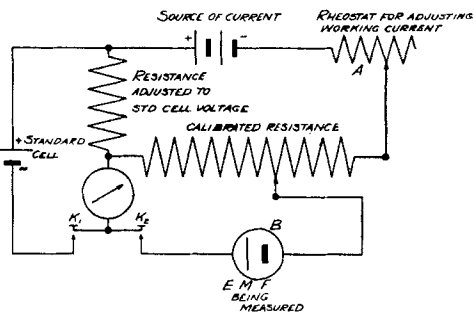

Fig. 2.

a two-volt storage battery. The E.M.F. being measured is for a cell, the cathode of which is a hydrogen electrode which is bathed with hydrogen and immersed in the solution being titrated. The anode is a saturated potassium chloride calomel electrode, which makes contact with the solution being titrated through the agency of a saturated potassium chloride salt bridge as recommended by Fales and Mudge.<sup>11</sup>

Contact is first made at  $K_1$  and the resistance (A) regulated so that there is no galvanometer deflection when the circuit is momentarily closed. This step is to obtain from the storage battery the same difference of potential as that which was used when the wire was calibrated. Contact is then broken at  $K_1$  and made at  $K_2$ . This puts the unknown E.M.F. (B) in circuit and throws the standard

cell out. The calibrated resistance is then so regulated that the galvanometer will not deflect. The difference of potential ( $E$ ) can then be read on the potentiometer to hundredths of a millivolt. We are now familiar with the hydrogen electrode, the Nernst formula, and two common experimental methods of determining the ( $H^+$ ) of a solution.

The use of this set-up to determine the ( $H^+$ ) at which an indicator will change color is at once apparent. A solution of acid is placed in the beaker containing the hydrogen electrode, with a suitable amount of indicator added, and is titrated with a base in the ordinary way until the desired color change takes place. The potentiometer or millivoltmeter is then read and the  $p_H$  value corresponding to the difference of potential obtained is calculated. The  $p_H$  values at which various indicators change will be found listed in modern quantitative texts.<sup>12</sup>

The use of the above set-up for titrating acidity is also apparent. Let us assume that we wish to titrate a weak acid whose aqueous solution is very dark and cannot well be decolorized. The use of indicators is, therefore, impossible. A measured amount of the acid is placed in the beaker with the hydrogen electrode and diluted to titrating volume. Let us assume that we wish to titrate to the exact neutral point, a  $p_H$  value of seven. The potentiometer is therefore set at a value of 0.6614 volts and the titration is started in the usual way, with the galvanometer deflecting, let us say, to the right. Standard alkali is run in until one drop causes a deflection of the galvanometer in the opposite direction. Or in case of the millivoltmeter set-up alkali is run in until the reading on the millivoltmeter is 0.6614 and the galvanometer shows no deflection. This affords a very accurate method for acidity titrations to any desired  $p_H$  value as the end-point.

Another valuable use of this set-up is the determination of whether or not a particular acid solution can be analyzed quantitatively by use of indicators and if so which indicators are suitable for the titration. In order to do this we must construct titration curves for the electrometric titration. The solution is titrated in the presence of the hydrogen electrode as outlined above. The difference of potential between the hydrogen electrode and the calomel half cell is measured for each cubic centimeter of alkali added, except in the region of pronounced changes in the ( $H^+$ ) where readings are more frequently taken. The cubic centimeters of alkali used are then plotted against the corresponding  $p_H$  values of the solution and the titration curve thus constructed.

When a strong acid is titrated with standard sodium hydroxide the titration curve resulting is shown in Graph No. 2. When a volume of 22 cc. of alkali have been added we obtain an increase in  $p_H$  value from 3.5 to 9.5. This tells us that an accurate indicator titration can be run and that our choice of an indicator is not greatly restricted. Any one of the three common indicators, phenolphthalein, litmus and methyl orange could be accurately used.

When a weak acid is titrated, the curve resulting is shown in Graph No. 3.

The sudden increase in the  $p_H$  value here took place when 25 cc. of sodium hydroxide had been added. The break in the curve is pronounced enough to allow of a suitable indicator end-point but it is evident that we are much more restricted in our choice of an indicator. An indicator changing at  $p_H$  values between 6.5 and 9.5 must be chosen. Either litmus or phenolphthalein ought to

function well, the latter being preferred. The upward bulge in the curve before a  $p_H$  of 5 is reached is caused by the repression of the ionization of the acid due to the increasing concentration of its anion. No such repression was observed in the strong acid titration curve.

When sodium carbonate is titrated electrometrically with  $N/10$  hydrochloric acid, the titration curve is shown in Graph No. 4.

This titration curve is most illuminating. Two breaks are observed which make indicator end-points possible. The first break occurs when 11 cc. of acid have been added and registers the point where all  $\text{CO}_3$  has been changed to  $\text{HCO}_3^-$  and carbonic acid begins to be formed. The second break occurs when just twice as much acid has been added. Then all  $\text{HCO}_3^-$  has been changed to carbonic acid and one drop of  $N/10$  hydrochloric acid in excess has been added. It is also observed that phenolphthalein changing at a  $p_H$  value of about eight is a possible indicator for the first end-point and that methyl orange changing at a  $p_H$  value of about four ought to indicate the second. The first break is also less pronounced

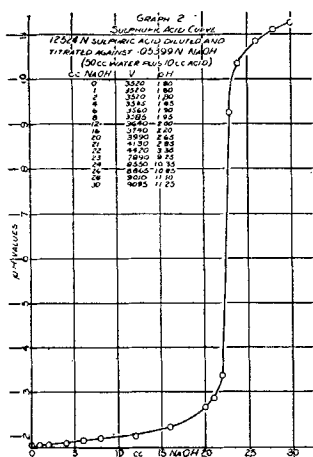

Graph No. 2.

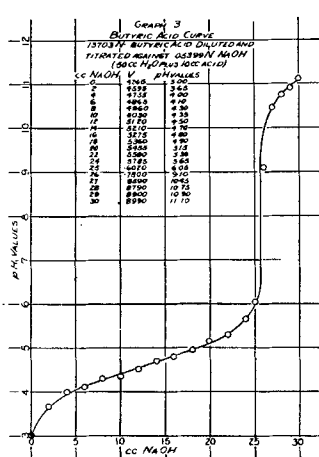

Graph No. 3.

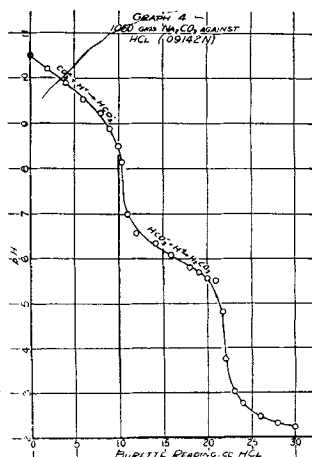

Graph No. 4.

than the second and thus records the well-known fact that when carbonate mixtures are being titrated the phenolphthalein end-point is less satisfactory than the methyl orange end-point. This first end-point could be improved upon if an indicator changing color at a lower  $p_H$  value was substituted for phenolphthalein.<sup>13</sup>

The following curve (Graph No. 5) was constructed for a mixture of sodium hydroxide and sodium carbonate.

This curve is as we would expect it to be. It shows the two possible end-points. The amount of acid (AB) used upon reaching the phenolphthalein end-point is shown to be greater than the volume (BC) used from this point to the methyl orange end-point and the method of calculating such mixtures quantitatively is justified.

For a sodium carbonate and bicarbonate mixture the results are shown in Graph No. 6.

The so-called phenolphthalein volume AB is here less than the methyl orange

volume BC and our method of calculating such mixtures is also justified. The bicarbonate in equation (2) is that which has been made by half neutralizing carbonate ion. The bicarbonate represented by equation (3) is that which was originally present in the sample as such.

The following Graph,<sup>14</sup> No. 7, is one showing the relationship between cubic centimeters of *N*/10 alkali and *p*<sub>H</sub> values when a mixture of very weak acids

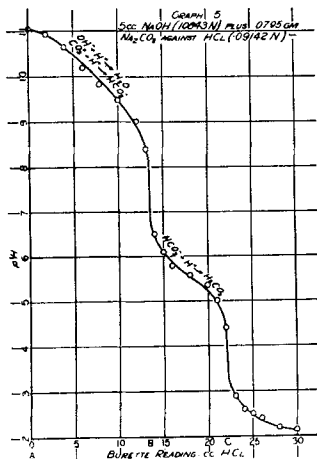

Graph No. 5.

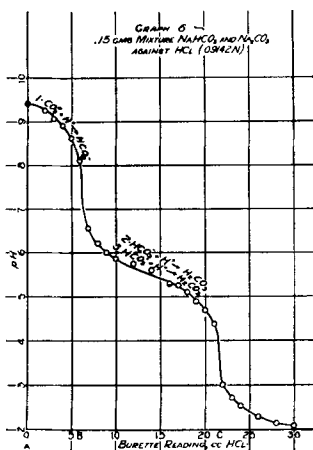

Graph No. 6.

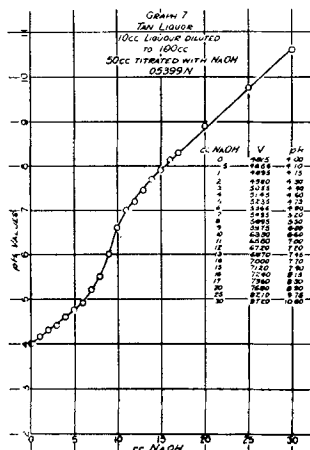

Graph No. 7.

is titrated. This particular sample was a vegetable tan liquor. An examination of this curve shows that no accurate indicator end-point is possible. At no time during the titration do we get a sudden enough increase in *p*<sub>H</sub> value to make possible a suitable color change of any indicator. If the acidity of this solution is to be accurately determined, a method involving some other principle must be used. This can be accomplished by an electrometric titration as above outlined. This, however, necessitates the use of fairly complicated and expensive apparatus and a knowledge of physical chemistry which is not possessed by all analysts.

The following simpler method<sup>15</sup> can, therefore, be used to better advantage. The apparatus employed is shown by the following diagram.

C is a cadmium half cell containing 12 per cent cadmium amalgam in contact with a solution of cadmium sulphate and potassium iodide. This cadmium half cell constitutes the negative pole of the cell and the hydrogen electrode constitutes the positive pole. When the difference of potential between these two electrodes is zero, there is no deflection of the galvanometer. K is a key to make and break the circuit. G is a galvanometer. H is a Hildebrand type of hydrogen electrode. S is a saturated potassium chloride salt bridge to reduce

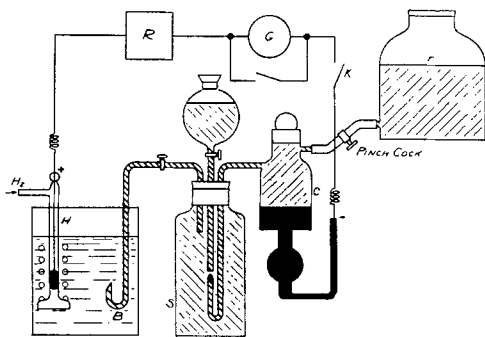

Fig. 3.



contact potentials and  $r$  is a large reservoir of the electrode solution which is being used in the cadmium half cell.

The operation of the set-up is quite simple and needs little comment. The solution being titrated is placed in Beaker B with the hydrogen electrode as indicated in the diagram. Standard alkali is then run in until one drop causes a deflection of the galvanometer in the opposite direction, thus clearly indicating the end-point of the titration.

When a strong acid is being titrated with a strong base, the addition of one drop of 0.05  $N$  sodium hydroxide at the end-point will cause a wide deflection of the galvanometer in the opposite direction. When very weak acids are titrated, the falling off of the galvanometer deflections is very gradual and at the end-point a very slight movement in the opposite direction is caused by the addition of one drop of the alkali. The end-point obtained, however, is very accurate, as the slightest motion of the galvanometer is easily detected by the eye, whereas the color change of the indicator that would result from the slightly decreased hydrogen-ion concentration could not be easily detected. Thus, when working with very weak acids, even in colorless solutions, the cadmium half cell is preferable and affords a more accurate method of titration than does the use of indicators.

Various investigators have recommended the use of electrodes made of glass or other inert material without the use of hydrogen. One of the earliest publications along this line is by Haber and Klemensiewicz.<sup>16</sup> Later Van der Meulen and Wilcoxson<sup>17</sup> showed that successful breaks in the titration curve could be obtained by the use of inert electrodes in the absence of hydrogen and that accurate results could be obtained with this simplified set-up.

Phyllis T. Kerridge<sup>18</sup> describes a method involving the use of glass electrodes in measuring  $p_H$  values with an accuracy of 0.02. Not more than five minutes are required for the determination, the volume of solution used is less than one-half cubic centimeter and the sample is returned unaltered at the end of the experiment.

The system used is represented as follows:

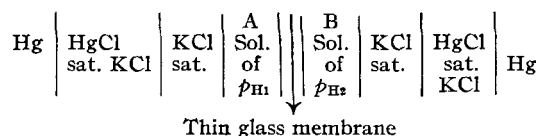

The E.M.F. of the system is represented by the expression

$$E = \frac{RT}{F} (p_{H_1} - p_{H_2}) + E_g$$

$E$  = total E.M.F.

$E_g$  = Potential at glass membrane.

About 0.50 cc. of solution of known  $p_H$  value is placed in part of set-up marked (A) and a larger amount of a buffer solution of known  $p_H$  value is put in (B) and the E.M.F. ( $E$  standard) of the system measured. (A) is then emptied, thoroughly washed and the solution of unknown  $p_H$  value ( $p_{H_x}$ ) put in. The E.M.F. ( $E_x$ ) is again measured and  $p_{H_x}$  is calculated as follows:

$$p_{H_x} = p_H \text{ standard} = \frac{E \text{ standard} - E_x}{57.7} \text{ at } 18^\circ \text{ C.}$$

The utility of this method in biological work where frequently only small amounts of the material worked with are available, is plainly evident.

Another method of determining acidity without the use of indicators, involving quite a different principle is the conductivity method, first indicated by Kohlrausch.<sup>19</sup> The apparatus here employed is the ordinary Wheatstone Bridge arrangement as is shown below.

AB is the bridge, C the sliding contact and R a high-known resistance which should be so regulated that the bridge reading at the start of the titration is about fifty centimeters. This resistance is maintained constant throughout the determination. (V) constitutes the unknown resistance in a conductivity cell. (I) is a small induction coil which changes direct current from a dry cell to alternating current in order to minimize polarization effects. Since a galvanometer cannot be accurately used with alternating current, a telephone receiver, tuned to the vibration of the induction coil is substituted. When the contact (C) is at the point of balance there is no buzz in the receiver. The platinum electrodes in the conductivity cell are coated with platinum black to increase their surface,

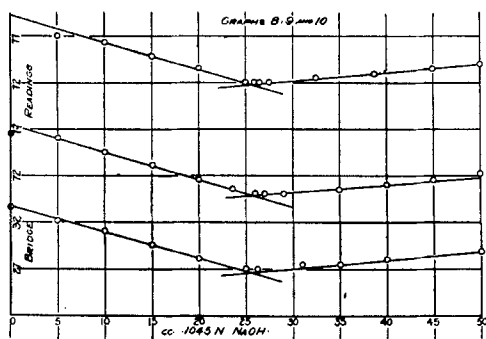

Graphs Nos. 8, 9 and 10.

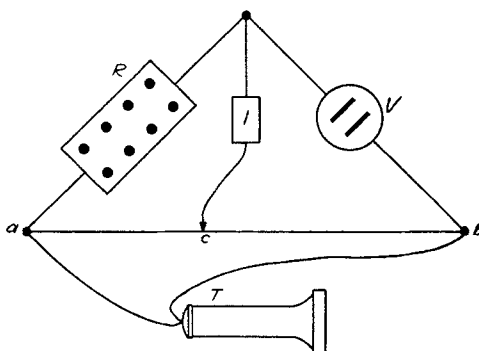

Fig. 4.

thus making a better sound minimum possible. In a more delicate set-up a Kohlrausch Bridge is substituted for a Wheatstone Bridge and the actual conductance at the different intervals in the titration plotted against the cubic centimeters of alkali used.

This method, as is well known, depends upon the ability of a solution to conduct the electric current. This conductivity being determined by the concentration and mobility of the ions which it contains. The velocities with which different ions travel toward the oppositely charged electrode vary greatly and have been determined by migration experiments. When a strong acid is being titrated with a strong base, the conductivity of the solution will progressively decrease due to the decreasing ( $H^+$ ) and the formation of an equivalent amount of the less mobile sodium ion. When, however, the neutralization of the acid is complete, a further addition of alkali will cause a greatly increased concentration of the mobile hydroxyl ion and hence an increased conductivity. Thus when bridge readings are plotted as ordinates against the number of cubic centimeters of alkali added and straight lines drawn through the points on each side of the point of minimum conductivity we obtain a break in the curve which can be used as the end-point.

The preceding graphs were developed by Little and MacWhood during an investigation of the determination of sulphuric acid in pickle solution. The pickle solution is an aqueous solution of salt and sulphuric acid. The acid cannot always be accurately determined by use of indicators due to the fact that the pickle is frequently highly colored and due to the salt error which would be experienced by most indicators. Graphs Nos. 8, 9 and 10 show results obtained when the pickle solution was titrated with 0.1045 *N* sodium hydroxide using the ordinary Wheatstone Bridge set-up.

An examination of these graphs shows that the breaks obtained give definite points of neutralization which check each other very closely. They also agree with results obtained by use of the hydrogen electrode where 10 cc. of the pickle solution required 25.30 cc. of 0.1045 *N* NaOH.

Graph No. 11 shows results obtained when the solution was titrated with standard barium hydroxide solution. The decrease in the conductivity is greater here due to the fact that the barium ion does not replace the hydrogen ion but is precipitated as barium sulphate and thus removed from solution. Graph No. 12 shows the results of a titration using the Kohlrausch Bridge.

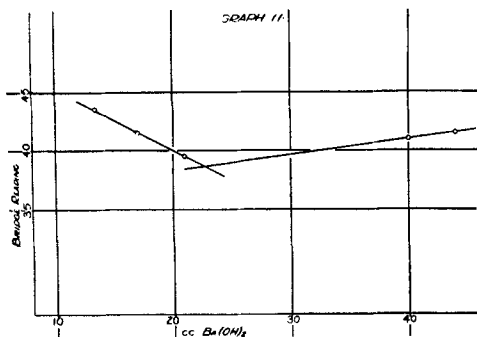

Graph No. 11.

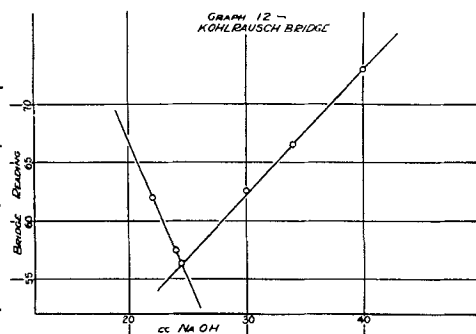

Graph No. 12.

Although the graphs shown above give the desired end-point, they are rather shallow due to the conductivity of the large amount of sodium chloride present. Sulphuric acid alone titrated with sodium hydroxide would give a much sharper break in the curve.

Nothing has been stated in this discussion in regard to colorimetric methods involving the use of buffer solutions as have been prepared and studied by Clark and Lubs,<sup>20</sup> Walpole<sup>21</sup> and others. These methods are rapid, quite accurate and exceedingly useful but are dependent upon the hydrogen electrode as a primary standard.

There are also on the market many special types of apparatus designed to give ( $H^+$ ) or  $p_H$  values directly.<sup>22,23</sup> These are very useful and will be increasingly used but involve no new principle.

For further study of this subject use should be made of Clark's work<sup>24</sup> and the splendid bibliography which he has made available. Prideaux<sup>25</sup> has also furnished valuable information on the subject.

#### BIBLIOGRAPHY.

- (1) Kolthoff, *Z. anorg. allgem. Chem.*, 132, 318 (1924).
- (2) Popoff and McHenry, *JOUR. A. PH. A.*, 14, 473 (1925).

- (3) Wagener and McGill, *JOUR. A. PH. A.*, 14, 288 (1925).
- (4) Giesy, *JOUR. A. PH. A.*, 12, 855 (1923).
- (5) Krantz, *JOUR. A. PH. A.*, 14, 294 (1925).
- (6) Sorensen, *Biochem. Z.*, 21, 131 (1909).
- (7) Nernst, *Z. physik. Chem.*, 4, 129 (1889).
- (8) Helmholtz, *Ann. der Physik.*, 44, 42 (1890).
- (9) Hildebrand, *J. Am. Chem. Soc.*, 35, 847 (1913).
- (10) Klopsteg, *Ind. Eng. Chem.*, 14, 399 (1922).
- (11) Fales and Mudge, *J. Am. Chem. Soc.*, 42, 2434 (1920).
- (12) Fales, "Inorganic Quant.," p. 143.
- (13) Little and Durand, *J. A. L. C.*, 20, 19 (1925).
- (14) Beans and Little, *Ind. Eng. Chem.*, 17, 252 (1925).
- (15) Beans and Little, *Ibid.*, 17, 413 (1925).
- (16) Haber and Klemensiewicz, *Z. physik., Chem.*, 67, 385 (1909).
- (17) Van der Meulen and Wilcoxson, *Ind. Eng. Chem.*, 15, 62 (1923).
- (18) Phyllis T. Kerridge, *Biochem. J.*, 19, 611 (1925).
- (19) Kohlrusch, *Ann. Phys. Chem.*, 26, 225 (1885).
- (20) Clark and Lubs, *J. Biol. Chem.*, 25, 479 (1916).
- (21) Walpole, *J. Chem. Soc.*, 105, 2501 (1914).
- (22) Keeler, *Ind. Eng. Chem.*, 14, 395 (1922).
- (23) Goode, *J. Am. Chem. Soc.*, 44, 26 (1922).
- (24) Clark, "The Determination of Hydrogen Ions."
- (25) Prideaux, "The Theory and Use of Indicators."

---

## CHEMICAL AND BIOLOGICAL ASSAY OF DRUGS. CASCARA SAGRADA.\*

BY J. B. BERARDI, PH.G., B.S., AND M. C. CANAN, B.S.

### PART I.

Color tests for the identification of Cascara Sagrada as outlined by the U. S. P. are indefinite and inadequate. Other drugs such as Frangula, Aloes, Rhubarb, Senna, and Ergot give very similar color reactions by these methods so that it seems impossible to make a positive identification of any of them by this test.

More attention should be paid to the color reactions of Cascara Sagrada for it seems that the coloring matter is a fairly reliable index of the activity of the drug.

In the present work, the method for identification of Cascara, as outlined in the U. S. P. was carried out on Frangula, Aloes, Rhubarb, and Senna. It was found that color variations were so inconstant that they would not suffice for identification; therefore, we have attempted other methods which are as follows:

#### ETHER EXTRACTION METHOD.

Fluidextracts of Cascara, Aloes, Frangula, and Rhubarb were prepared according to the U. S. P. method. Ten cc. each of the fluidextracts were completely extracted with ether, until a color was no longer imparted to the solvent and the solvent gave no color reaction with ammonia water. During the extraction, troublesome emulsions were often encountered. The aqueous residue left after

---

\* This paper forms part of a thesis presented in partial fulfilment of the requirements for the degree of Master of Science in Pharmacology in the Graduate School of the University of Illinois.